



FUEL MANAGEMENT SYSTEMS



DISPENSERS



KITS



PUMPS



METERS



NOZZLES

PANTHER AC

FEATURES

- COMPACT AND STURDY DESIGN
- READY TO USE
- EASY TO INSTALL
- INTEGRATED FILTER

The PIUSI PANTHER AC is a versatile self-priming rotary electric vane transfer pump available in three versions (56 - 72 - 90) particularly suitable for dispensers, fixed fuel transferring system and other industrial applications. It is equipped with a by-pass valve and an incorporated filter to stop impurities.

PERFORMANCE

UP TO
90 L/MIN

FLOW RATE

AC
CONTINUOUS DUTY

POWER



PANTHER 56 (flanges not included)



PANTHER 72 - PANTHER 90 (flanges included)

PACKAGING

CODE	WEIGHT		PACKAGING			N. BOXES / EUROPALLET	
	KG	LBS	MM	INCH	PCS/BOX	✈	🚛
PANTHER 56							
FO0730000	7,4	16,3	345X175X255	-	1	60	84
000731000	7,4	16,3	345X175X255	-	1	60	84
000733000	7,4	16,3	345X175X255	-	1	60	84
PANTHER 72							
000732000	7,9	17,4	345X175X255	-	1	60	84
000735000	7,9	17,4	345X175X255	-	1	60	84
PANTHER 90							
FO0733020	8,2	19,9	345X175X255	-	1	60	84



FILTRATION



TANK MONITORING



HOSE REEL



ACCESSORIES



MERCHANDISE



AIR



ANTIFREEZE



AdBlue®



BIODIESEL



DIESEL



FOOD



GASOLINE



GREASE



KEROSENE



OIL



WATER



WINDSCREEN

CHART

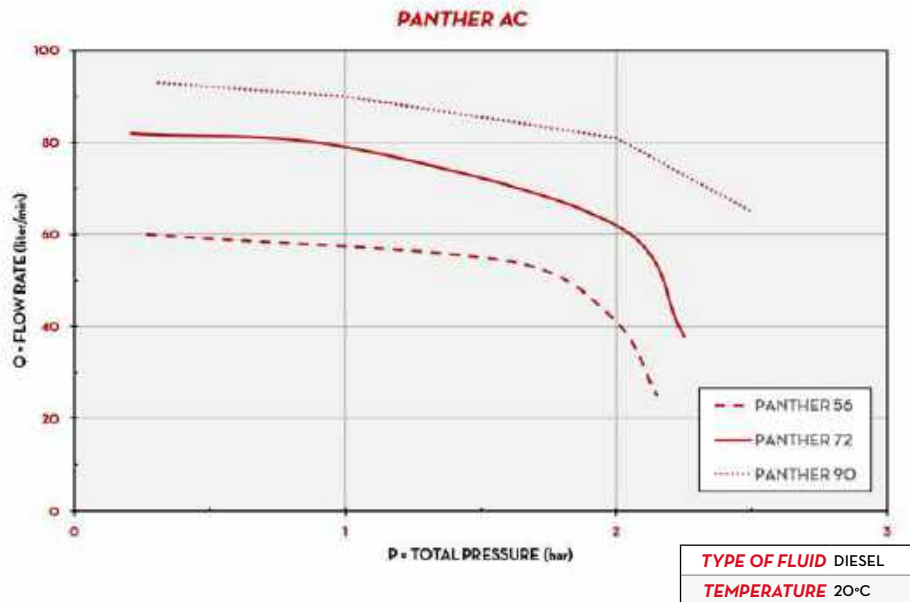

IN THE BOX

- PANTHER AC PUMP
- INSTRUCTION MANUAL

DETAILS



DIMENSIONS

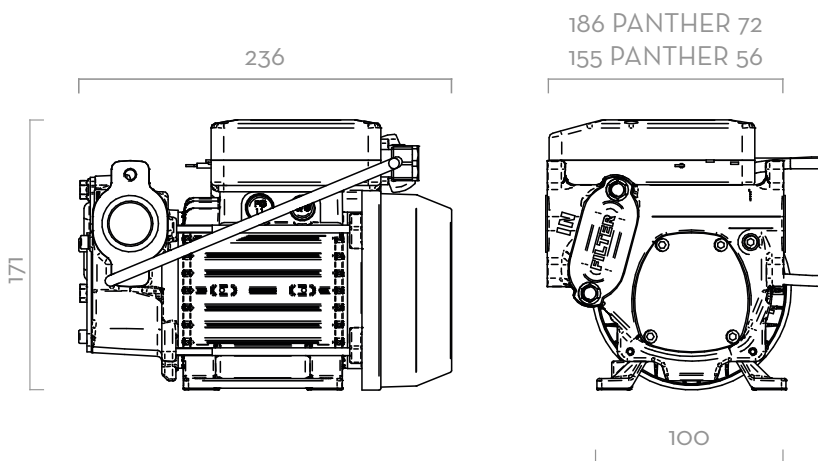

Dimensions expressed in millimeters

MATERIALS

- BODY: CAST IRON
- ROTOR: SINTERED STEEL
- VANES: TECHNOPOLYMER
- SHAFT: STEEL



PUMP



TANK

- > MAX 6M (20FT),
- > SUCTION HOSE Ø 1" MIN,
- > MAX SUCTION HEIGHT:
 - 2M (7FT) W/O NON RETURN VALVE
 - 4M (14FT) W NON RETURN VALVE

TECHNICAL DATA

CODE	DESCRIPTION	FLUIDS TYPE	FLOW RATE		VOLTAGE				RPM	INLET OUTLET		FLANGE CONNECTION	BYPASS VALVE	INLET FILTER
			L/MIN	GPM	SINGLEPHASE MOTOR V/Hz	THREEPHASE MOTOR V/Hz	POWER WATT	AMP. MAX.		BSP				
PANTHER 56														
FO0730000	PANTHER 56 230/50	D	56	15	230/50	-	350	3	2900	1"	-	-	YES	YES
000731000	PANTHER 56 230/60	D	68	18	230/60	-	500	3,9	3400	1"	-	-	YES	YES
000733000	PANTHER 56 400/50	D	56	15	-	400/50	500	1,3	2900	1"	-	-	YES	YES
PANTHER 72														
000732000	PANTHER 72 230/50	D	72	19	230/50	-	500	4,2	2900	1"	YES	YES	YES	YES
000735000	PANTHER 72 400/50	D	72	19	-	400/50	500	1,6	2900	1"	YES	YES	YES	YES
PANTHER 90														
FO073302A	PANTHER 90 230/50	D	90	23,8	230/50	-	700	4,9	2900	1"	YES	YES	YES	YES

UPON REQUEST IT IS AVAILABLE WITH DIFFERENT VOLTAGES AND 60 HZ FREQUENCY.
() EXCEPT PANTHER 90

PANTHER AC